

11.6 Components Manual Layout

The Components manual grid, shown below, is very similar to the standard grid, but uses a single column across the full width of the page.

Exploded diagrams should appear on the left hand page, with the list of components on the right, for easy cross-referencing.

If parts lists are sufficiently long, they will continue on to 2 or more pages, in which case, the illustration on the Left hand page must be repeated.

Fig 19: Components manual grid

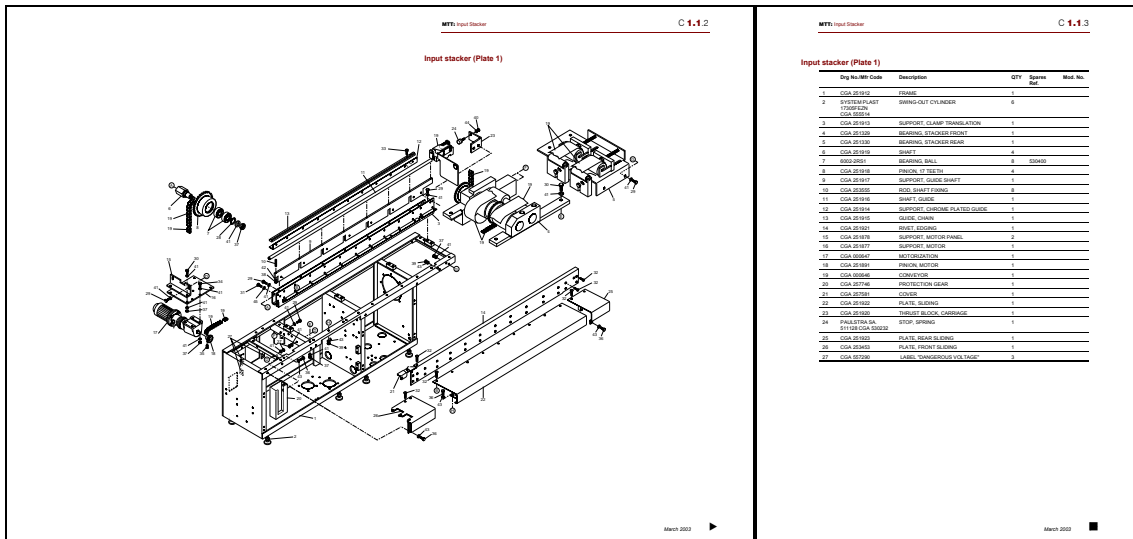

11.7 Page Breaks

Care should be taken that page breaks do not disrupt the sense of the text. This is particularly important when graphically structured items such as lists need to be broken. When broken, the benefits of their graphic structure are lessened.

'Widows' are single words appearing as the last line of the paragraph.

Widows are permitted except:

- when they appear at the top of the page: to avoid this, force a page break a line earlier so that one line appears above the widow
- in headings or captions when the widow is a short word: force a line break before the previous word or at the beginning of the phrase

'Orphans' are first or last lines of paragraphs that appear on their own at the bottom or top of a page. They can be avoided by forcing an early page break, so that at least two lines of a paragraph appear at the top or the bottom of the page.

A list of 6 or fewer items should never be broken across two pages, but should always appear as a single unit. When a list is broken across two pages, at least two items should appear in each resulting part. (See [Lists](#) on Page 30)

A listed item that takes more than one line should not be split so that part of the item appears at the bottom of one page and the other part at the top of the next page.

If a heading appears at or near the bottom of a page, it must have at least three lines of text following it before the end of the page. If it does not, you should force a page break before the heading so that it starts the next page.

